

# Инструкция по установке **CHEVROLET LACETTI** (2004-2013)

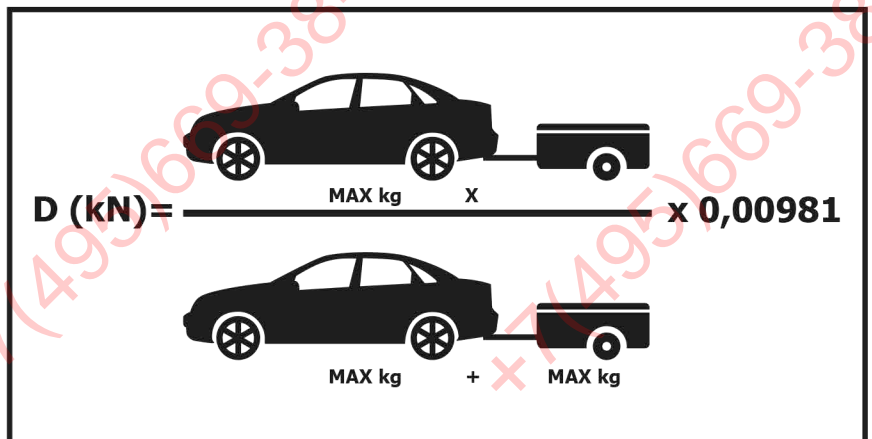

Арт.: F.1012.001

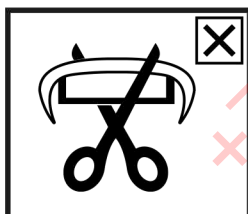

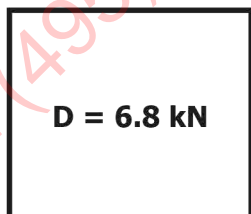
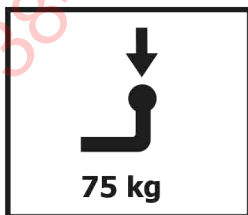
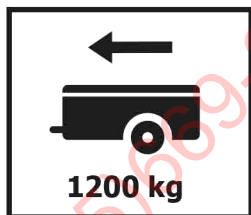
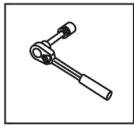

Вкрутить/выкрутить используя инструмент

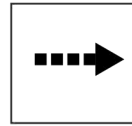

Движение

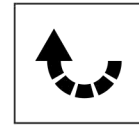

Поворот



Вкрутить/выкрутить не затягивая

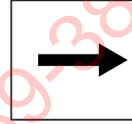

Расположение

### Используемый инструмент:

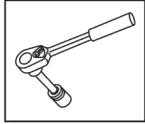

S - 17  
S - 19

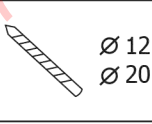
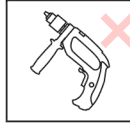

Ø 12  
Ø 20

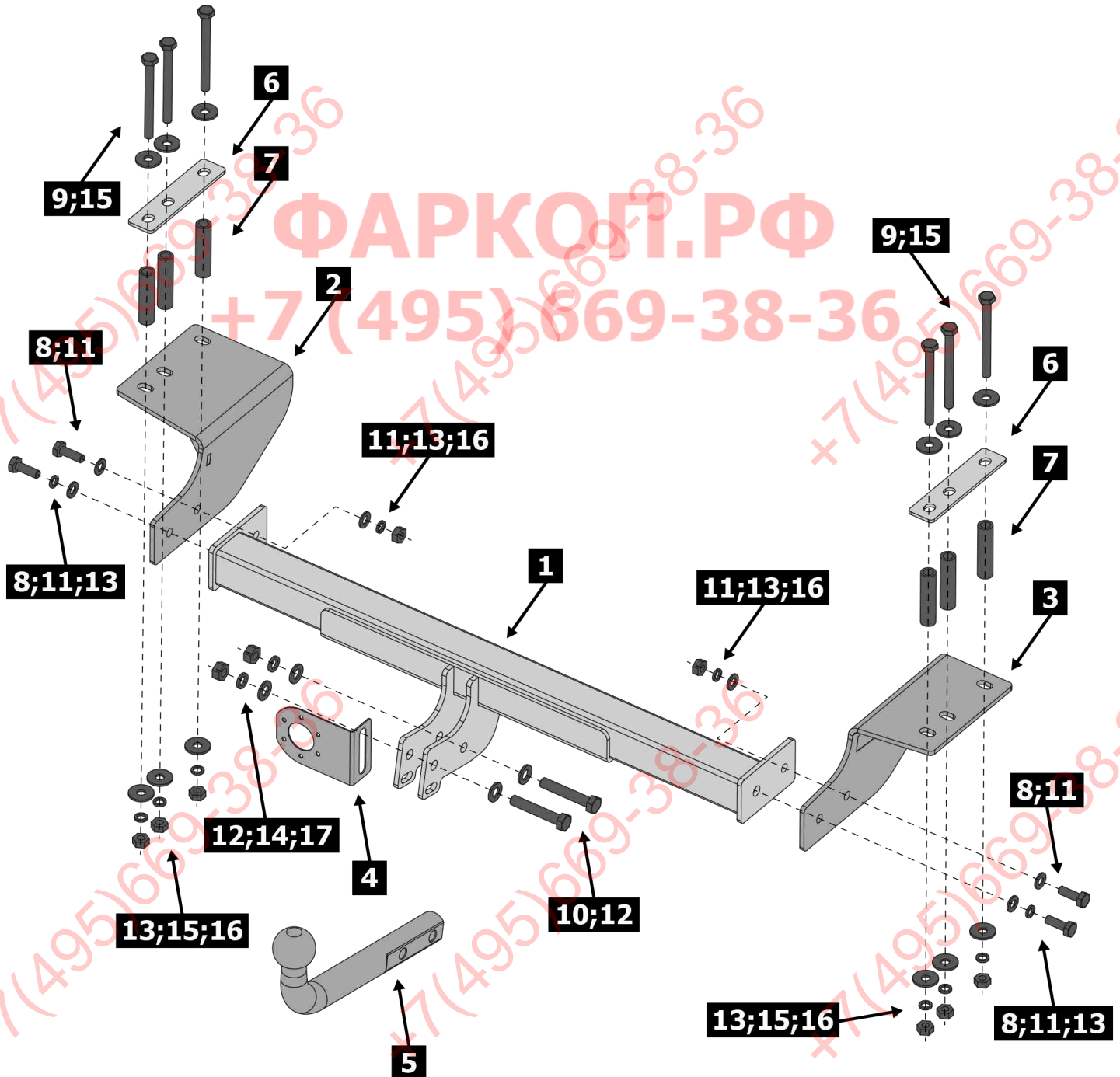

<b>1</b>	x1	Балка	
<b>2</b>	x1	Кронштейн балки левый	
<b>3</b>	x1	Кронштейн балки правый	
<b>4</b>	x1	Подрозетник	
<b>5</b>	x1	Крюк	
<b>6</b>	x2	Пластина	
<b>7</b>	x6	Втулка	
<b>8</b>	x4	M10x30	
<b>9</b>	x6	M10x110	
<b>10</b>	x2	M12x1,25x70	
<b>11</b>	x6	Ø10	
<b>12</b>	x4	Ø12	
<b>13</b>	x10	Ø10	
<b>14</b>	x2	Ø12	
<b>15</b>	x12	Ø10	
<b>16</b>	x8	M10	
<b>17</b>	x2	M12x1,25	

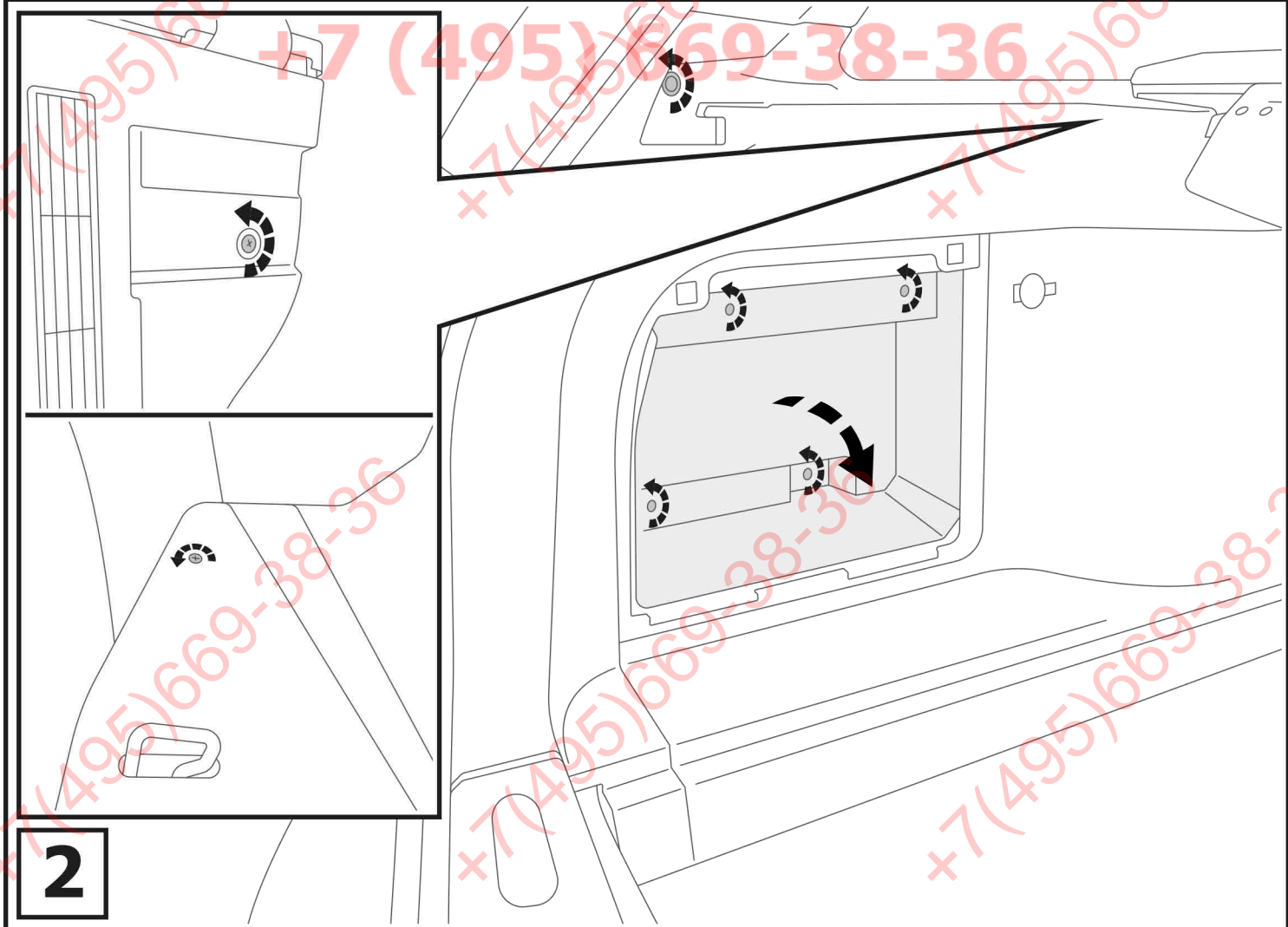
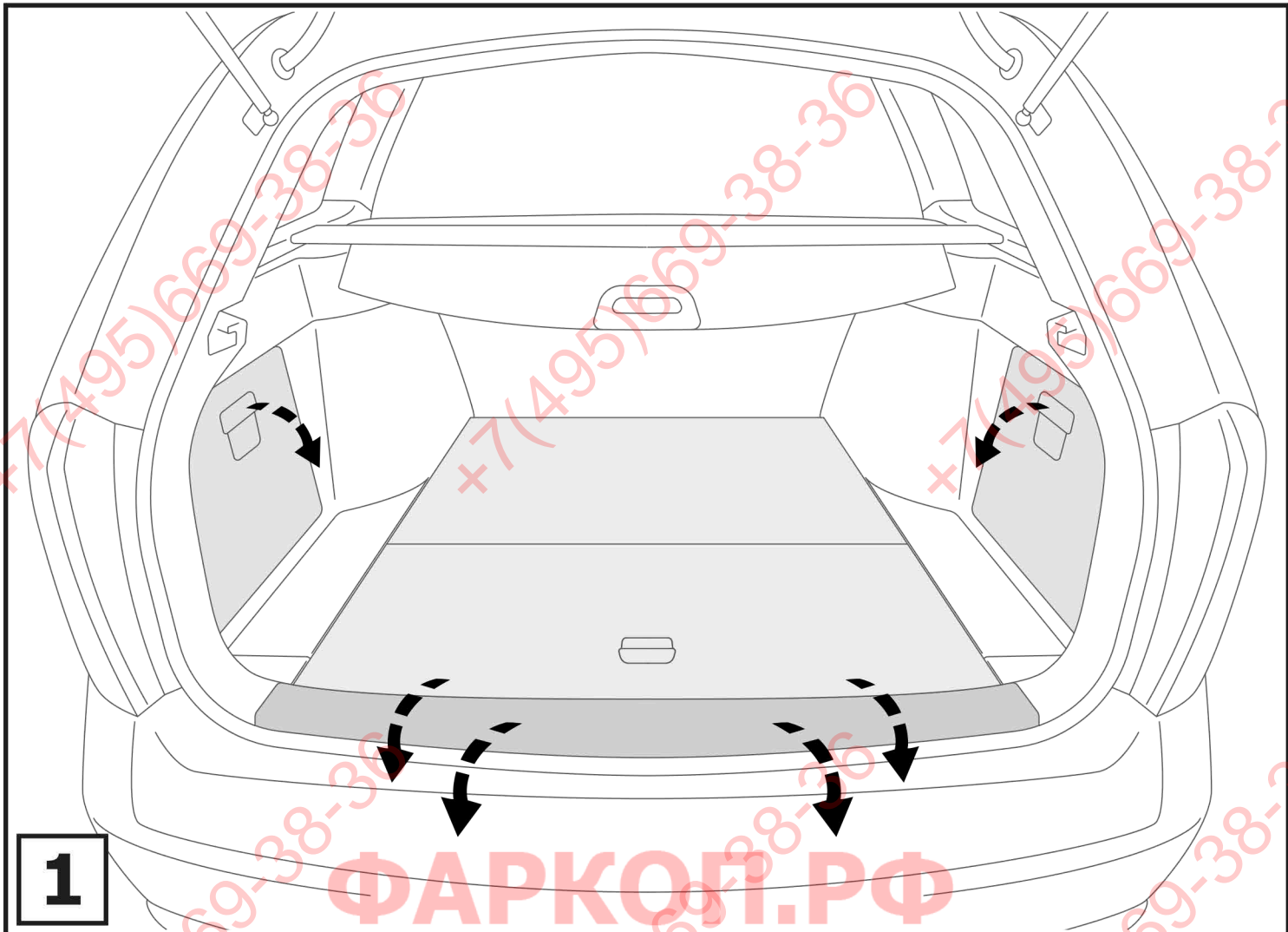

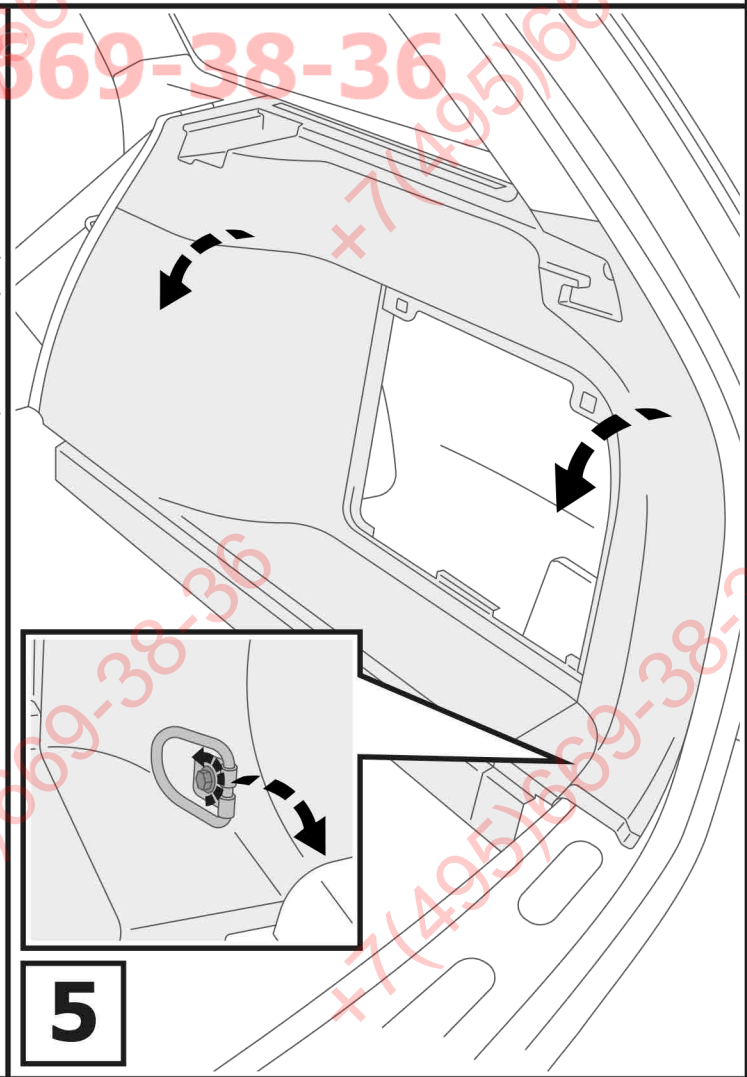
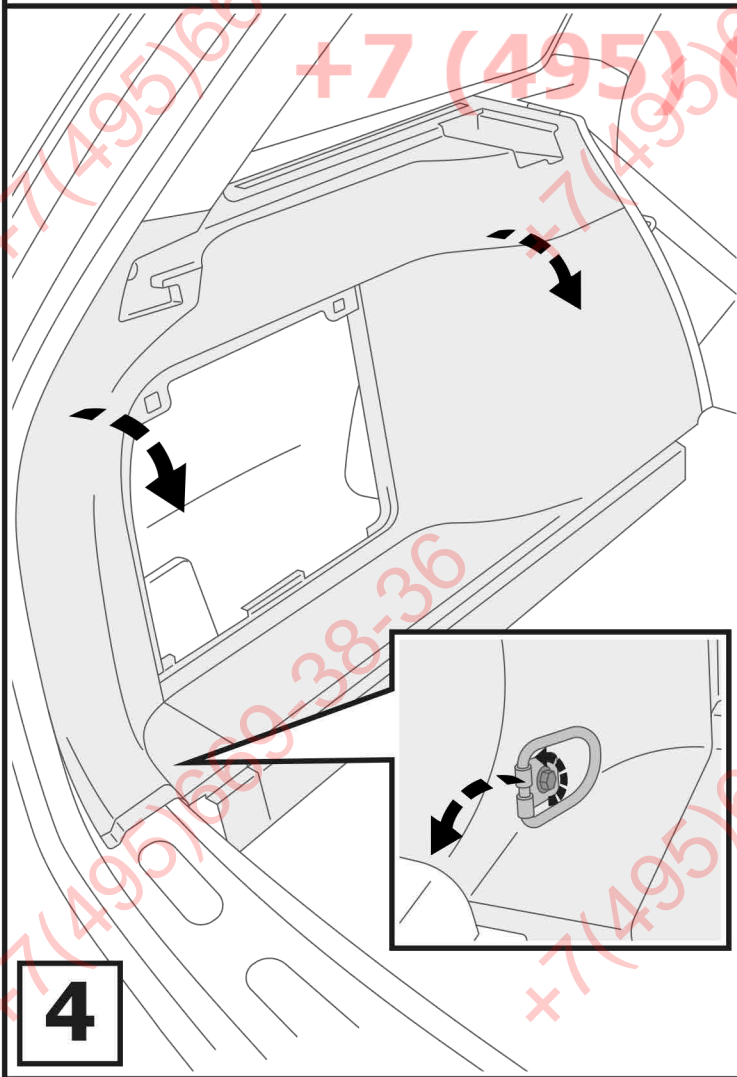
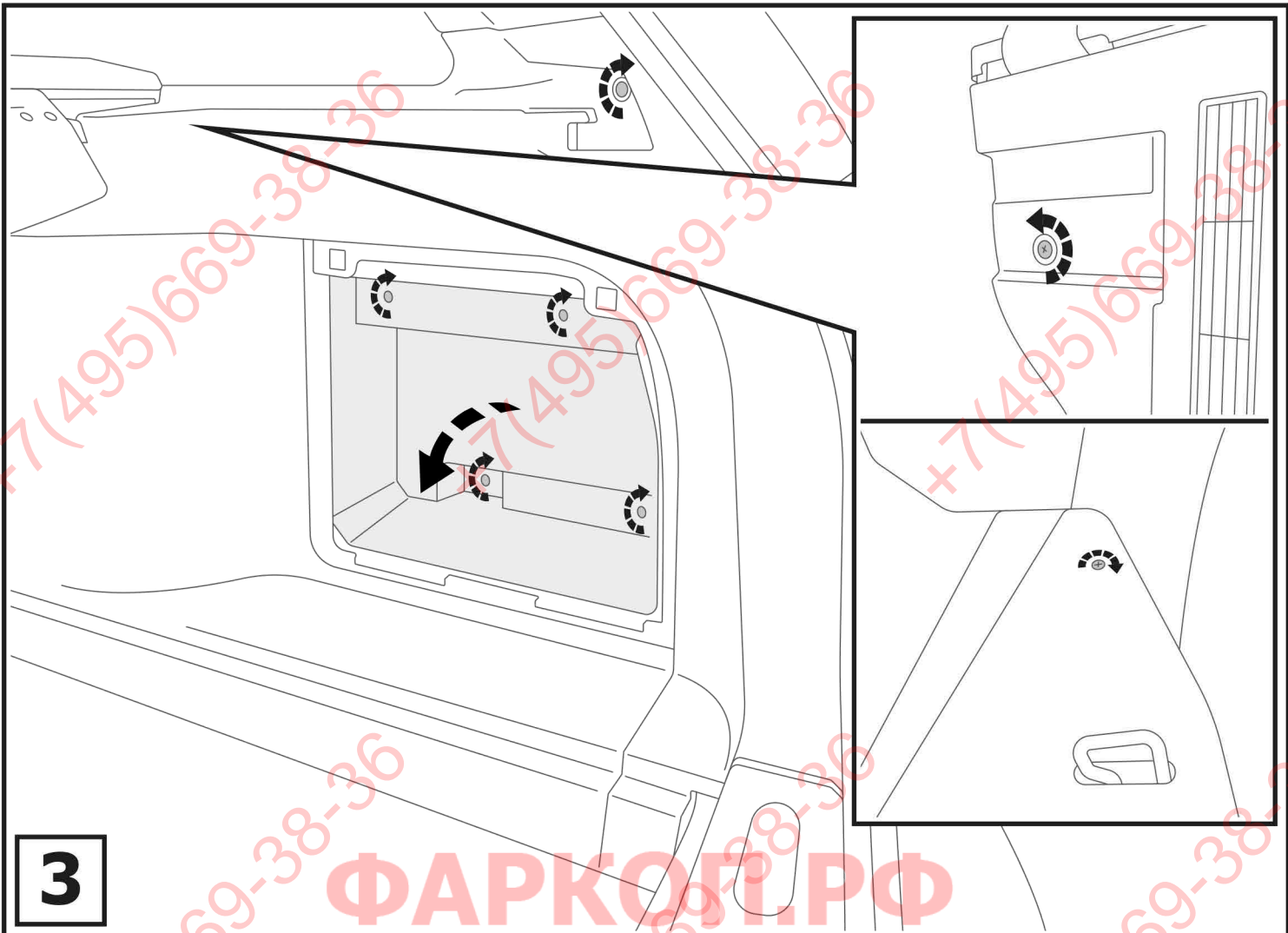

2

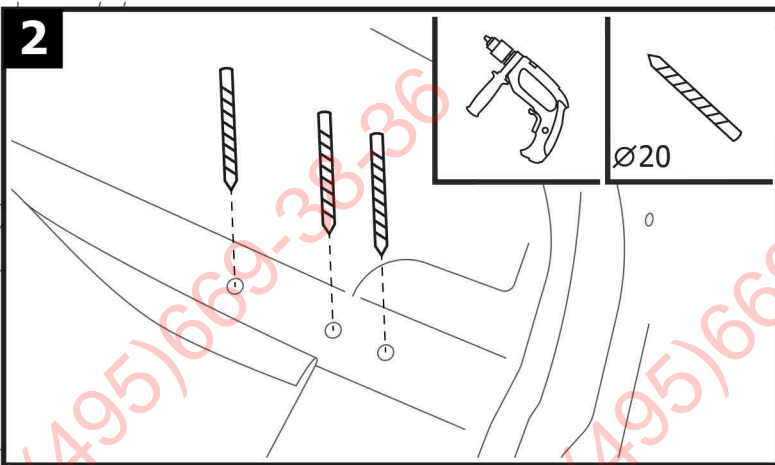

1

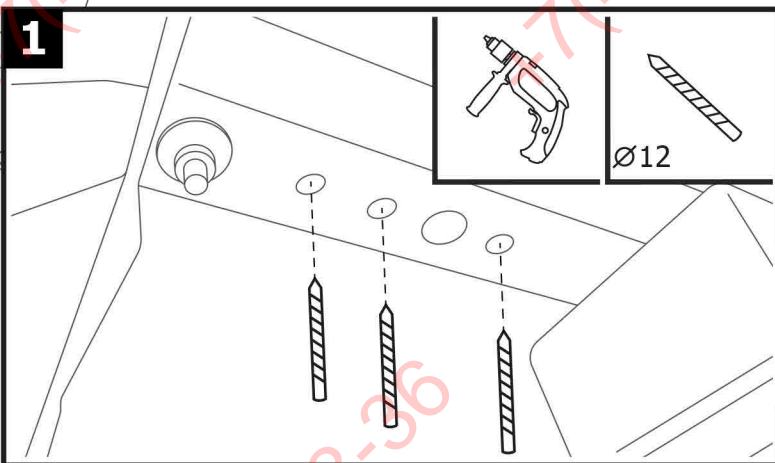

6

ФАРКОП.РФ

+7 (495) 669-38-36

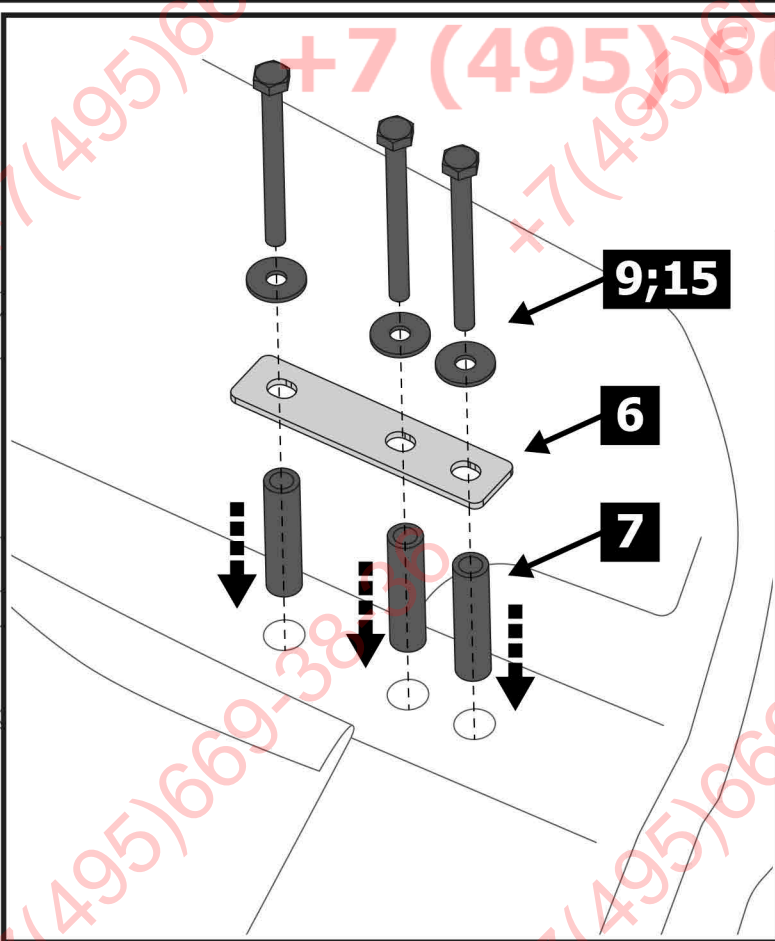

7



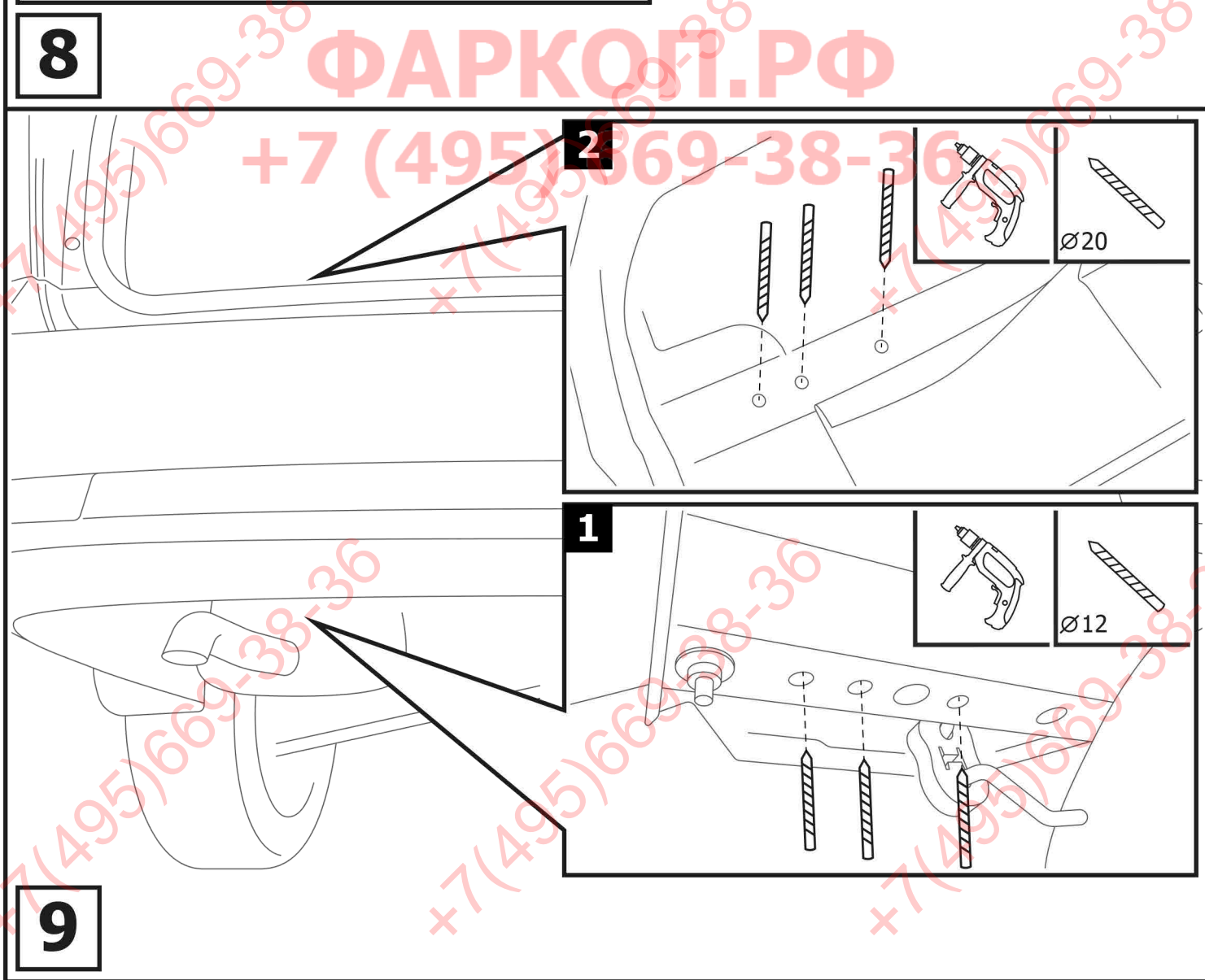
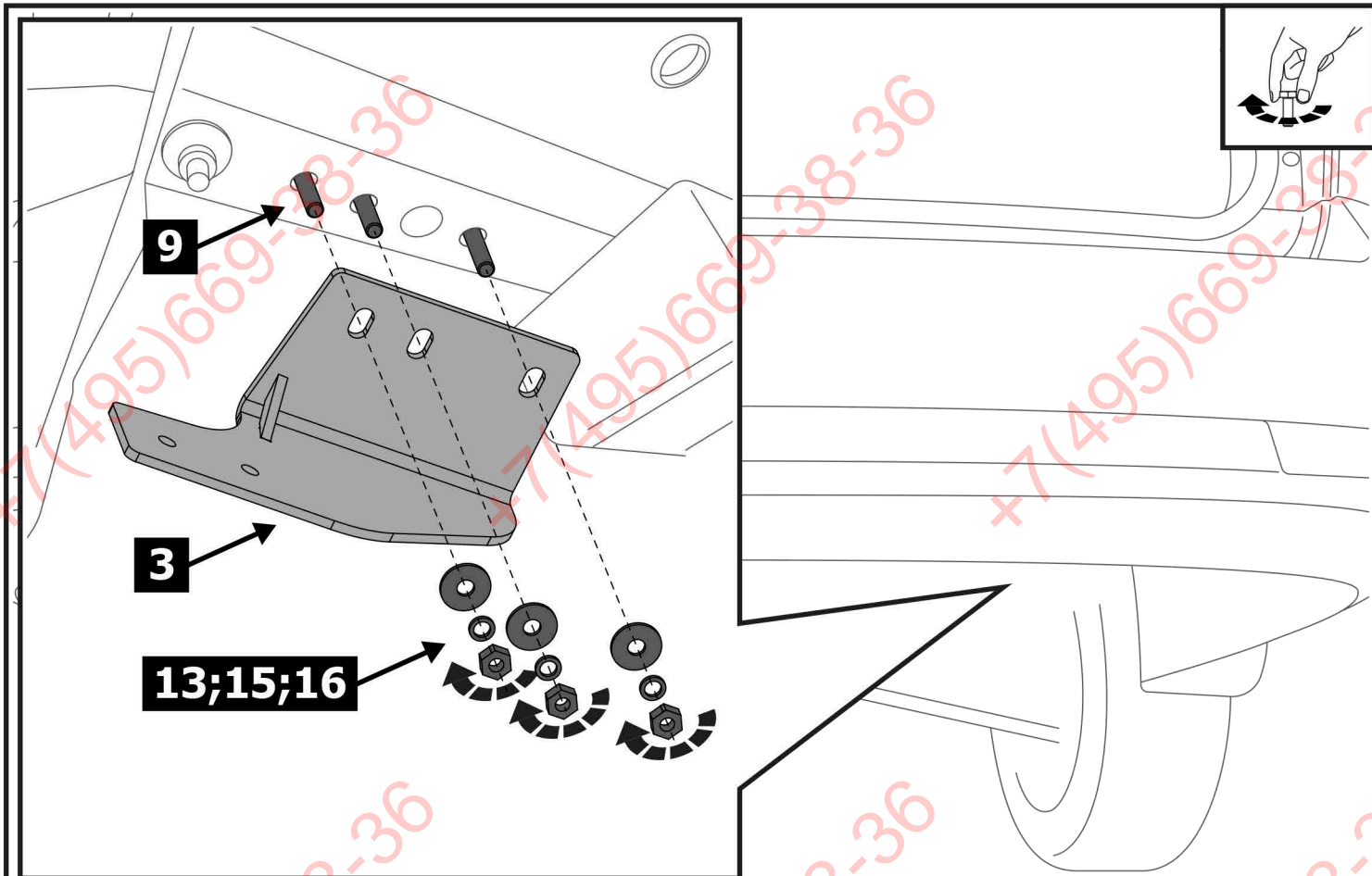

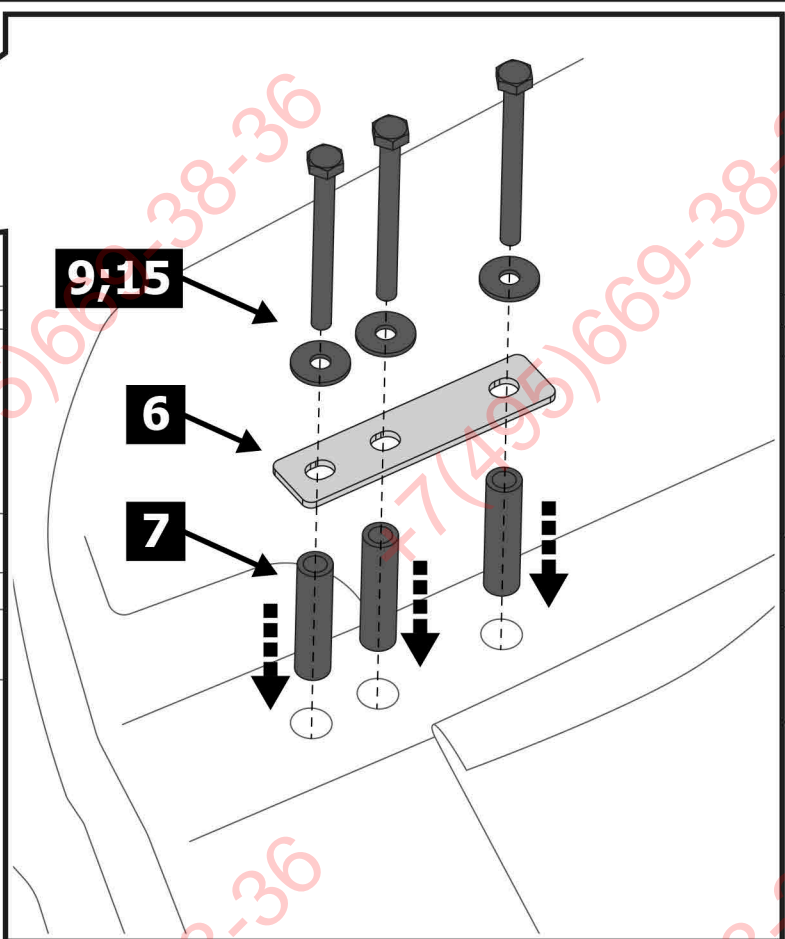
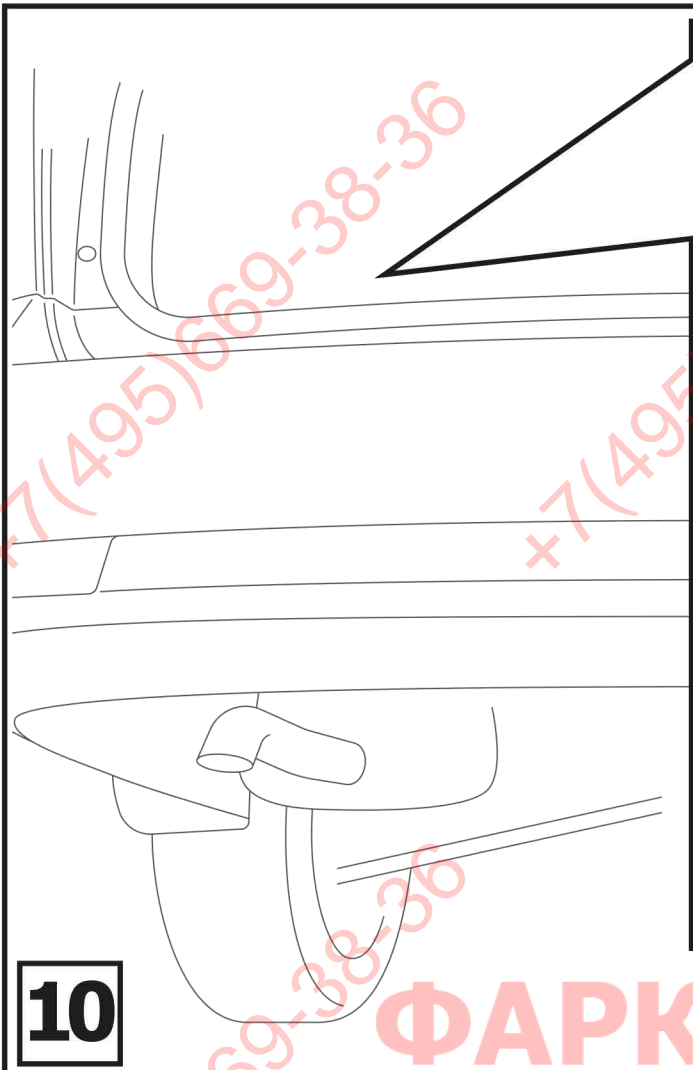

ФАРКОГ.РФ

+7 (495) 669-38-36

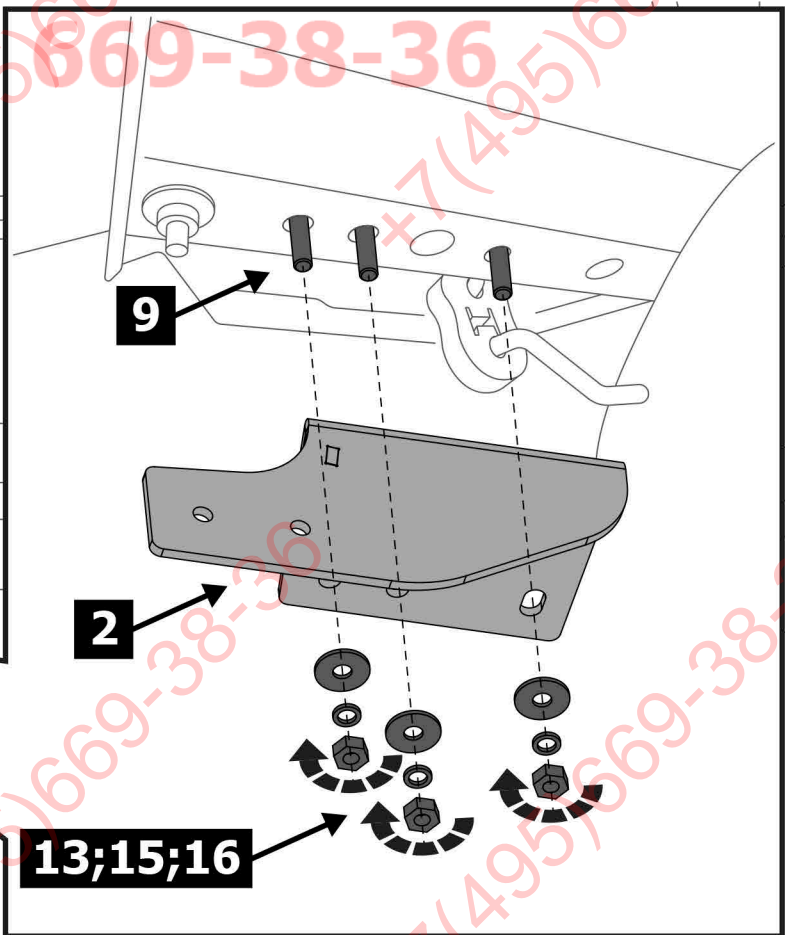
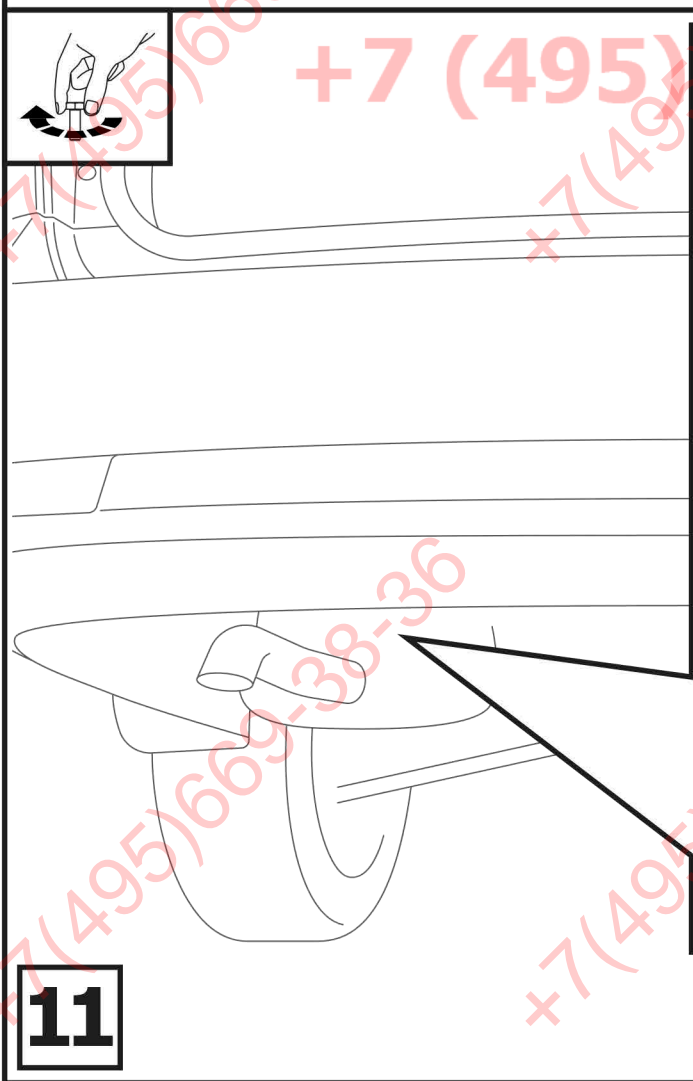



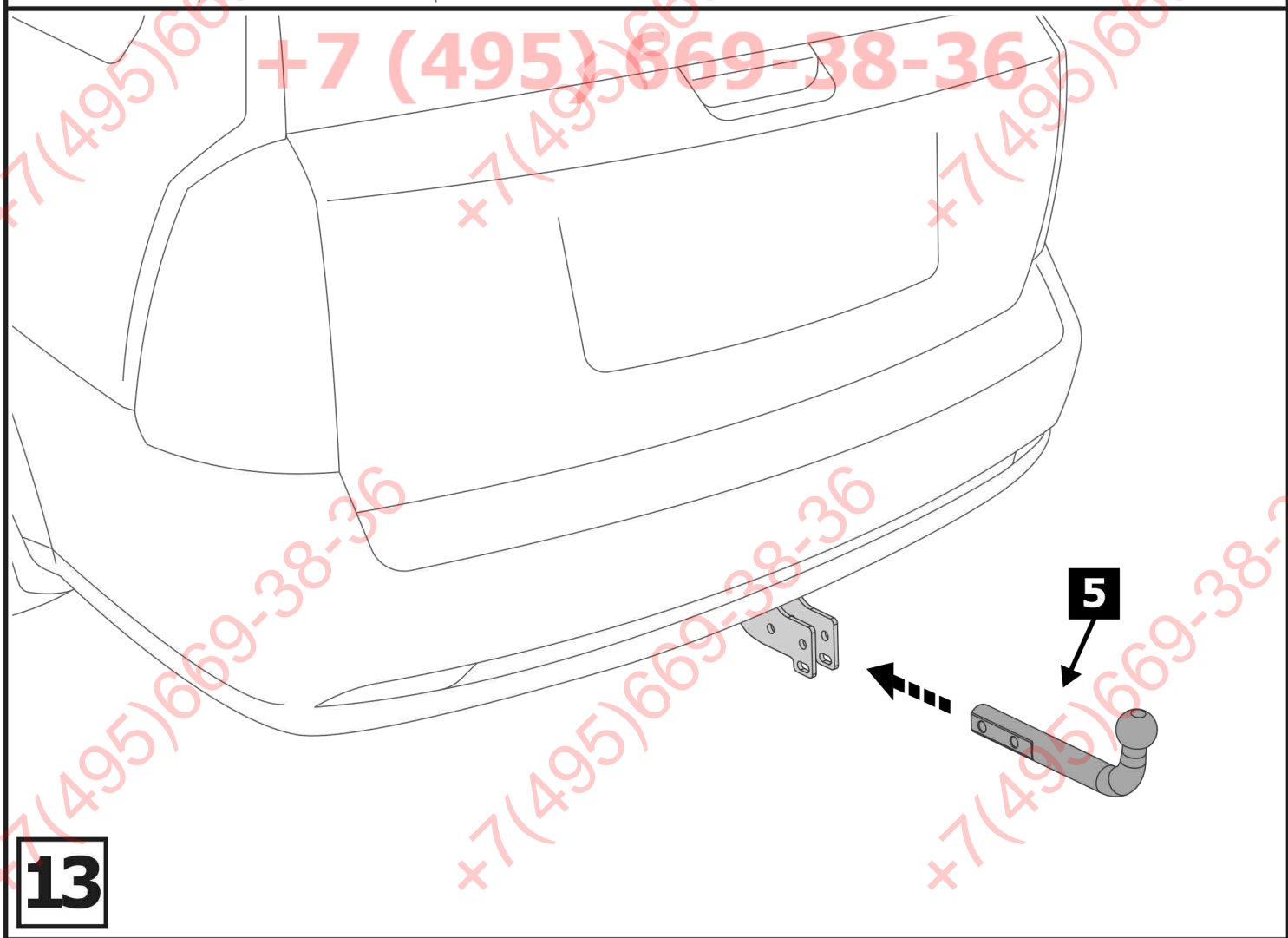
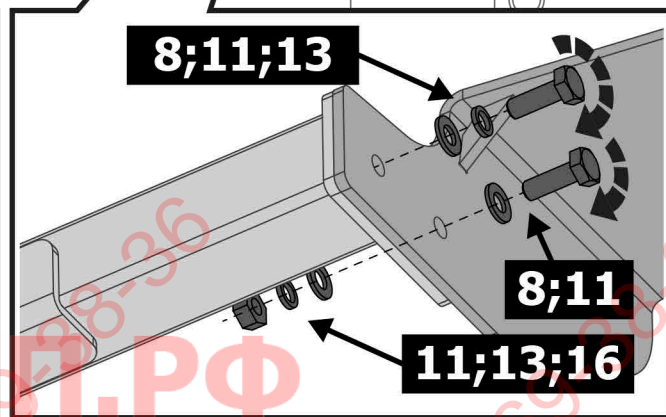
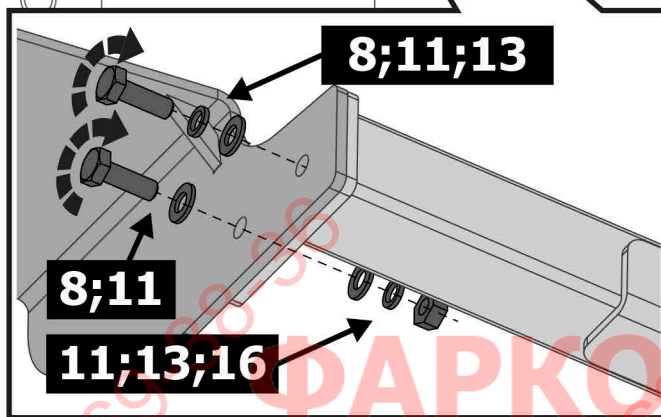
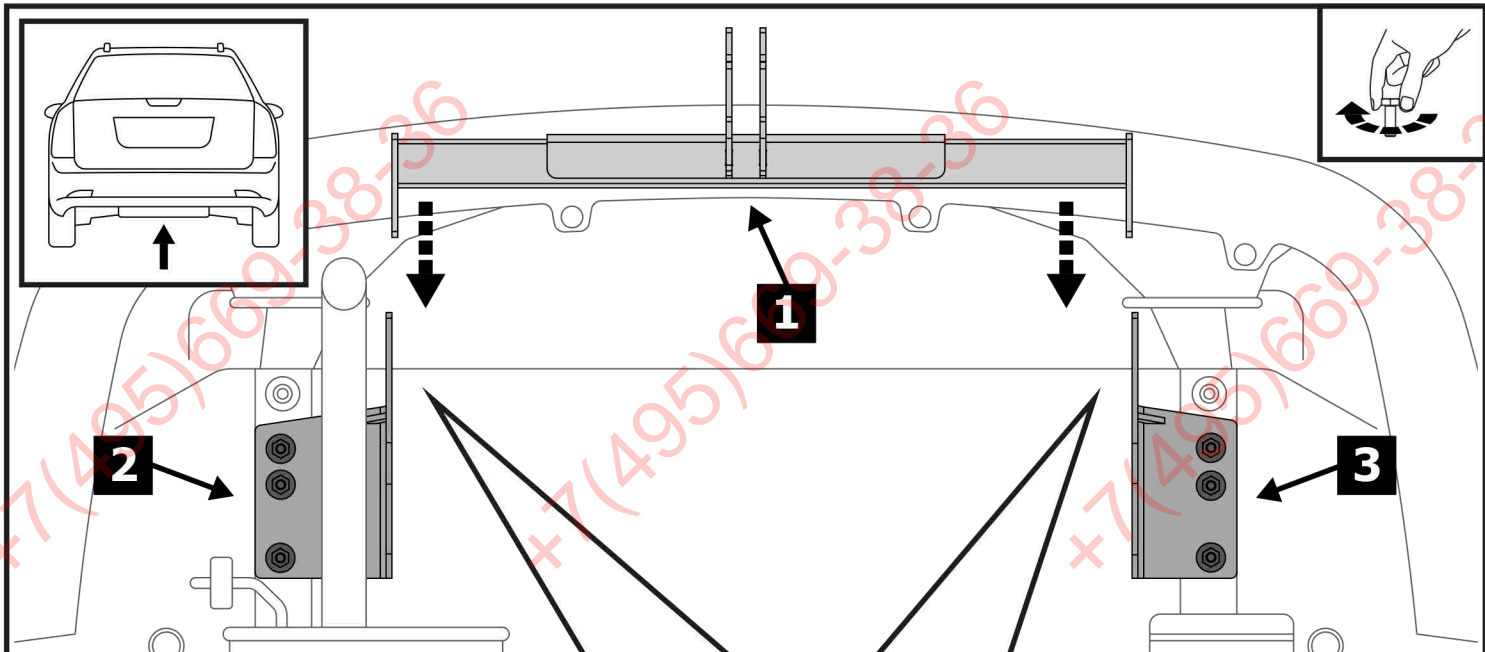

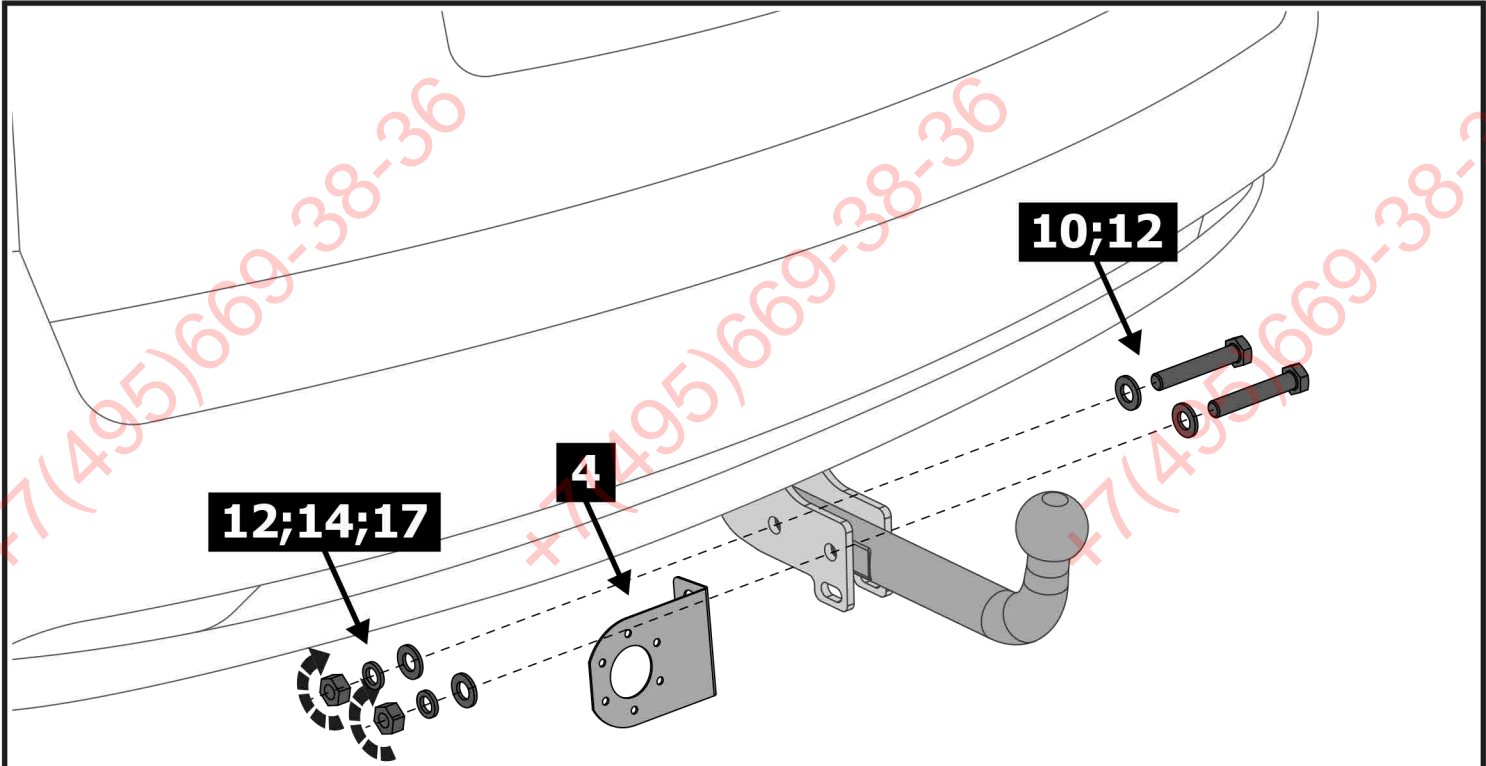

Затянуть все резьбовые соединения:  
M10 = 47 Nm; M12 = 84 Nm

**14**

**ФАРКОФ.РФ**

**+7 (495) 669-38-36**